

// New loading platforms and Hörmann Dock Control



New Loading Technology Products for 2011

Innovative solutions for increased efficiency



HRS/HRT loading platforms HLS hydraulic dock leveller



The HRS and HRT loading platforms are an ideal basis for a loading house (shown: HRT)

High quality at inexpensive prices

Our HRS and HRT loading platforms, as well as our HLS dock leveller, offer the highest level of function, safety and efficiency at a price that won't hurt your budget. Thanks to a sturdy steel construction and well-dimensioned hinges, they are designed for rated loads of up to 60 kN, thus making them ideal for most loading situations.

HRS and HRT loading platforms: Start saving energy outside of the hall

The **HRS and HRT loading platforms** are an optimised combination of a hinged or telescopic lip dock leveller and a pedestal. They are easily and quickly fitted in front of the hall, providing you with a complete loading platform in no time at all. Inexpensive and energy-efficient: The thermal environment in the hall remains unaffected thanks to a consistent separation between the loading unit and the hall. There is no need to invest in additional insulation.

The cleverly designed HLS dock leveller

The HLS hinged lip dock leveller has been designed for conventional concrete work. The dock leveller is simply fitted in a prepared pit once the hall floor has been finished. The electrical connection for interconnecting the control and hydraulic unit is already pre-wired at the factory.



HLS dock leveller, for fitting in the hall

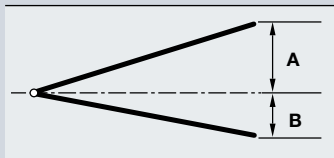

Working range

Lip lengths	HLS/HRS		HRT					
	Hinged lip		Telescopic lip					
	405		500		1000		1200*	
Ordering length	A	B	A	B	A	B	A	B
2000	235	305	270	350	325	410	-	-
2500	300	345	340	345	395	395	524	415
2750	330	340	370	400	430	430	455	455
3000	360	340	405	395	460	420	490	440

Dimensions in mm. The dimensions are maximum values with a gradient of 12.5% (approx. 7 degrees).

* Reduced rated load, 50 kN

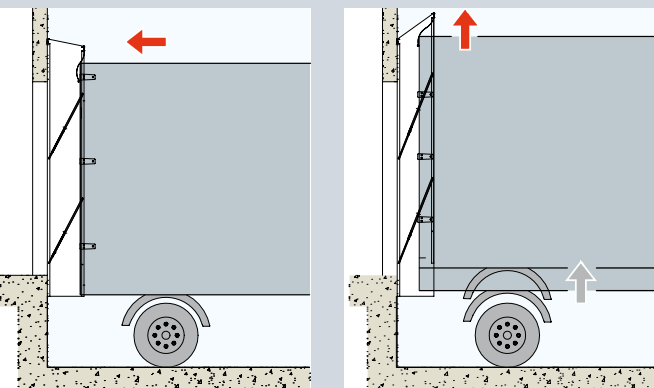

DSL-H flap dock shelter with liftable front frame

This dock shelter is particularly recommended in conjunction with interchangeable containers or if vehicles are docking to low ramps or are raised while docking. The top edge of a common dock shelter could be damaged when the container is raised to set it on its feet. The same applies if a vehicle that has docked to the dock shelter at a raised level rises during unloading. Thanks to telescopic link arms the front frame of the DSL-H dock shelter can move to adapt to vehicle movement, which minimises the risk of damage.

HTLV-3 hydraulic telescopic lip dock leveller

Dock leveller with 3-part telescopic lip for lorries and transit vans

The advantage of the HTLV-3 dock leveller: You can load and unload lorries and delivery vans at the same ramp.

A 3-part telescopic lip lets you use the same dock leveller for wide and narrow loading areas. The entire width of the telescopic lip (approx. 2000 mm) can be continuously extended for lorries. With a rated load of max. 60 kN, the HTLV-3 can be used like any other Hörmann dock leveller.

A simple switch on the control lets you only extend the centre section of the telescopic lip, making it ideal for delivery vans. An intelligent hydraulics system provides for the necessary weight compensation to ensure that the delivery van is not excessively loaded. In this state, the dock leveller can be loaded by up to 20 kN in accordance with EN 1398. The dock leveller follows the movement if the loading floor of the delivery van lowers during loading. This ensures proper positioning at every point.

TIP: Not every forklift is suitable for the resulting gradient. A longer dock leveller ensures a more favourable angle. Let us advise you!

To protect your investment during construction work, we recommend fitting at a later point. The dock leveller can easily be fitted in the prepared pit later on and welded to the edge brackets.

DL 1400 LED docklight

Energy-efficient: Energy consumption of only 16 watts

Long-lasting: Substantially longer service life, less susceptible to shocks

Effective: Better illumination of the centre of the loading space

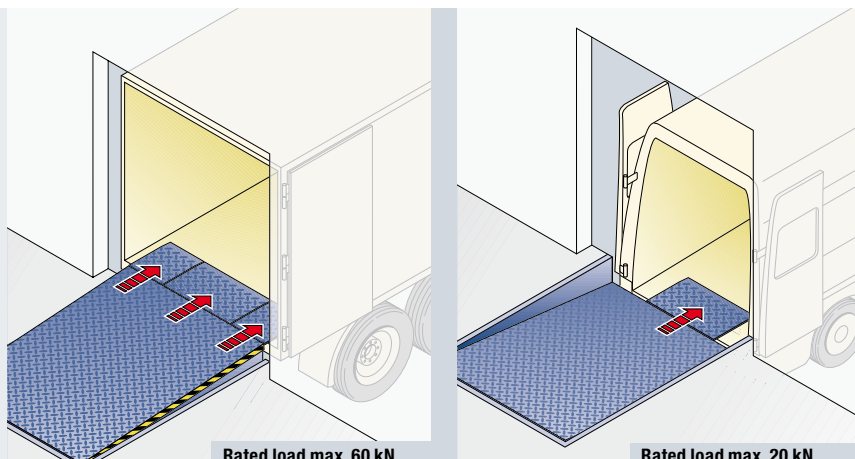

The 3-part dock leveller telescopic lip can be used over the entire width for lorries, or simply switch it to just extend the centre section with an optimum width for delivery vans.

The dock leveller can be locked to make sure that it does not cause any damage to the door. The dock leveller function is only released once the door is open. The control must have limit switch reporting in order to query the door position. It is not recommended for combination with manually operated doors.

Working range

Lip lengths	HTLV-3				
	Installation height	500*		1000*	
Ordering length		A	B	A	B
3000	795	420	570	490	650
4500	895	490	630	540	690

* The two side parts of the telescopic lip are retracted by a maximum of 450 mm in "delivery van" mode.



MLS and MRS mechanical dock levellers

For situations where small differences in height must be bridged

Mechanical dock levellers are a cost-efficient alternative in docking areas for vehicles with the same loading height. Small differences in height can be easily bridged if you select the right ramp height. With a standard rated load of 60 kN, the MLS and MRS mechanical dock levellers can deal with most demands. They are simple to operate via a control bar and of course fulfil the requirements for dock levellers in EN 1398.

MLS dock leveller: For fitting in a pit recess

The **MLS dock leveller** can be welded into a prepared recess quickly and easily. Cut-outs on the rear ensure a precise weld seam.

TIP: If you want to integrate the dock leveller in the hall floor during construction, a version with a cast box is also available.

MRS dock leveller: A complete loading ramp with side supports

The **MRS dock leveller** is quickly fitted without a recess in the hall and can even be attached to existing ramps. It is simply placed outside in front of the opening. Two side supports arranged either vertically (type **MRS-V**) or horizontally (type **MRS-H**) are already prepared to support the buffers.

It's your choice: A standard DB 15 version, an especially long-lasting DB 15 PU version or our HIB buffer with sensor.

Note: Please note the depth of the supports when selecting your dock shelter. We recommend using a Hörmann DSL flap dock shelter with 900 mm depth.



Dock leveller MLS
Fitting in the hall floor. Optional cast box.



MRS dock leveller
Fitting in front of the hall, either with vertical or horizontal supports

Working range

	MLS, MRS		
	Ordering widths	1750	2000
Working range	With max. 12.5% gradient in accordance with EN 1398: 68 mm above ramp level, 106 mm below ramp level		
Dock leveller length	approx. 735 mm		
Bearing surface	approx. 150 mm		
Support depth	Type MRS: 435 mm without buffers		

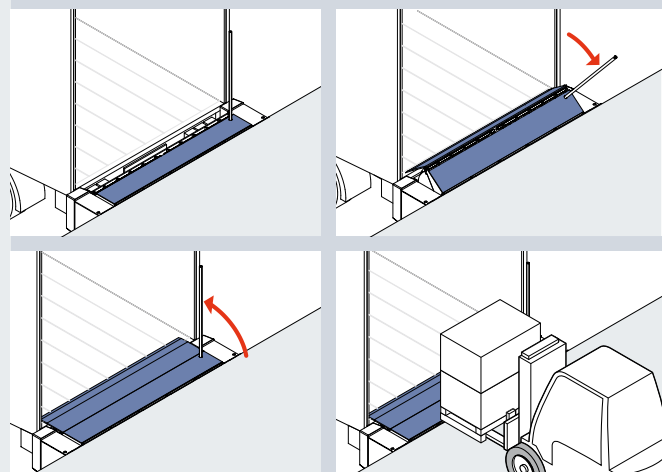

Easy operation via gas springs

Safe loading with Hörmann Dock Control



Hörmann Dock Control

Hörmann Dock Control reliably monitors and controls the entire loading process. Working as the control centre for comprehensive safety equipment, Dock Control evaluates information coming from e.g. the sensor wheel chock and HIB buffer and then controls specified blocking and signal functions.

1 2 3 Safe docking: The green traffic light signals that a lorry can dock at this loading bay. The HIB buffer with integrated sensor detects the distance between the lorry and the loading bay. Shortly before the lorry reaches its end position, the traffic light changes to yellow. The red traffic light finally indicates to the driver that the docking position has been reached.



4 Secure loading: The door can only be opened and the dock leveller operated after the lorry has been secured with the wheel chock.

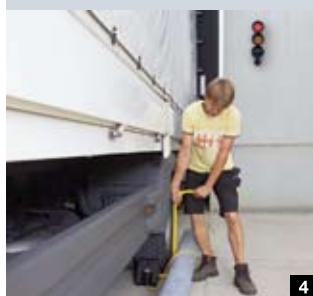

5 Controlled processes: The dock leveller is brought into position after the door is opened. The traffic light switches back to green and releases the loading unit.

6 Hörmann Dock Control warns of safety risks: Sensors in buffers and the wheel chock report back if the lorry unintentionally rolls away from the ramp or if the wheel chock is removed. The interior traffic light then switches to red and an acoustic alarm sounds.

Equipment

- Dock leveller with DR sensor
- Power-driven door with limit switch reporting
- HIB buffer with sensor
- Special control
- Interior red/green traffic light
- Exterior red/yellow/green traffic light
- WSPG wheel chock with optical sensor and integrated position sensor
- Alarm horn

The equipment can be adjusted depending on the customer's wishes and needs. **Let us advise you!**

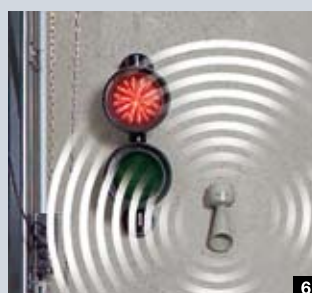

Practical planning: One partner for all your needs.

Industrial sectional doors

These space-saving door systems can be adapted to different industrial facilities using various track applications. This gives you planning reliability when building a new development or renovating. Hörmann offers you tailored solutions for every application: for instance fully-glazed ALS sectional doors for a clear view of the interior or double-skinned, 80-mm-thick DPU doors with high thermal insulation values that guarantee steady temperatures.

Rolling shutters and rolling grilles

Thanks to a simple construction with just a few components, rolling shutters are both economical and sturdy. Hörmann supplies rolling shutters in widths and heights of up to 11.75 m and 9 m respectively, or as special doors which are even higher. Numerous window and colour designs give you room for variety when designing your facility.

High-speed doors

Hörmann high-speed doors are used both inside and as exterior doors to optimise the flow of traffic, improve room conditions and save energy. The Hörmann programme includes vertically and horizontally opening transparent doors with flexible curtains, also in combination with industrial sectional doors and rolling shutters. Your advantage: SoftEdge technology with built-in crash-protection makes high-speed doors extremely safe and economical.

Service and maintenance

Only intact, professionally maintained systems ensure smooth production processes and secure traffic ways. An inspection and maintenance contract from Hörmann puts you on the safe side and you don't have to worry about anything. We will inspect your hall doors, fire-rated doors and loading technology equipment according to the legal requirements. Small deficiencies are addressed immediately, which helps you avoid expensive repairs. In emergencies, you can rely on our immediate service, so that your downtimes are kept to a minimum.

